

Clearance Double Water Bottle Filling Trough - One Only

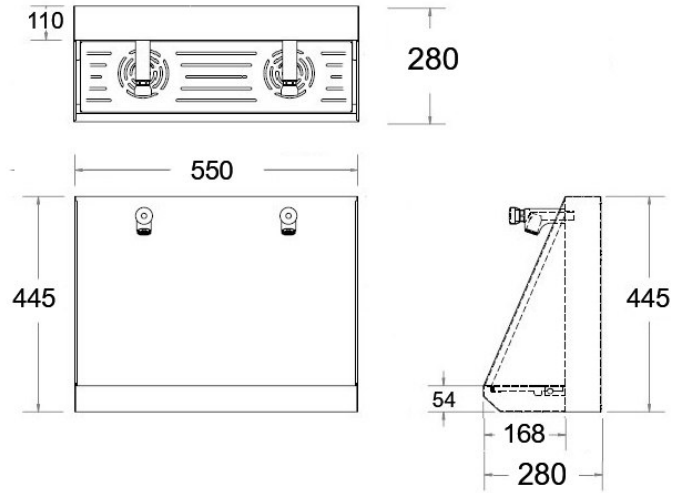

Product Code: 902

Two-User Wall Mounted Bottle Filling Trough – Clearance Item

Product Code: 902

This two-user wall-mounted bottle filling trough offers a convenient hydration solution for locations where multiple people may need to refill bottles at the same time. Designed for strength, hygiene, and ease of use, this dual-station unit is ideal for schools, gyms, transport facilities, workplaces, and leisure environments.

Please note: This listing is for a **single clearance unit**, available while stock lasts.

Dual Bottle Filling Stations

With two independent filling points, this unit allows two users to refill their bottles simultaneously, helping to minimise waiting times during busy periods. This makes it a practical choice for high-footfall areas where efficient bottle refilling is important.

Each station includes a push-button on/off tap, allowing users to control the water flow directly. This type of tap provides several advantages over traditional timed-flow systems:

- Prevents unnecessary water running after use
- Reduces overall water consumption
- Helps keep surrounding surfaces cleaner
- Provides a more responsive filling experience

Heavy-Duty Stainless Steel Construction

Manufactured from durable stainless steel, the trough is built to perform reliably in demanding environments. The brushed satin finish gives the unit a clean, modern appearance while helping resist marks from regular use.

The corrosion-resistant material also makes the unit easy to maintain and suitable for long-term installation in busy public settings.

Encouraging Reusable Bottle Use

Installing a dedicated bottle refill point helps promote sustainable hydration practices. By providing accessible drinking water, organisations can encourage staff, visitors, and students to use reusable bottles instead of single-use plastics.

This can help support:

- Reduction of disposable plastic waste
- Environmental and sustainability initiatives
- Lower waste disposal requirements
- Positive environmentally responsible behaviour

Space-Saving Wall Mounted Design

The wall-mounted configuration keeps floor areas clear while providing a convenient bottle refill point. The compact design makes it suitable for corridors, gyms, communal spaces, and public areas.

Installation height can be adjusted to suit the location, including accessible installations where required. The trough also incorporates fast-draining waste outlets, allowing for efficient water management.

Important:

To protect the internal components and ensure correct tap performance, a Y-strainer or filter must be fitted within the water supply system. Failure to install a suitable filter will invalidate the warranty.

Practical and Low Maintenance

The simple stainless steel construction allows the trough to remain hygienic, durable, and easy to clean. Designed with busy facilities in mind, it provides a reliable and straightforward bottle filling solution with minimal maintenance requirements.

Dimensions

- Length: 275mm
- Depth (front to back): 280mm
- Height: 445mm

Supplied With

- 38mm flush grated waste fitting
- Hinged grating to reduce splashing and assist cleaning
- Two WRAS approved on/off push button taps with brass backnuts

Delivery

This clearance unit is available for dispatch within approximately 1–2 working days

****All pictures shown are for illustration purpose only and may be subject to change without notice. Actual product may vary due to product enhancement.**

All dimensions shown are for guidance only and may be subject to change or alteration without notice. All items manufactured or purchased separately from a third party to fit our products should be checked against the actual dimensions of the physical product before purchase. We will not be liable for third party costs and consequential loss associated with the items not fitting third party components.**