

Combined Drinking Fountain & Bottle Filler- Adult Height

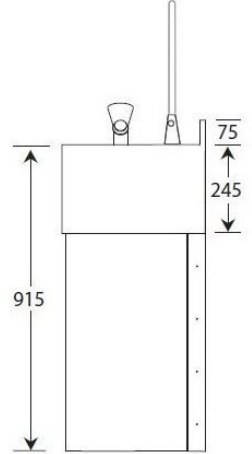
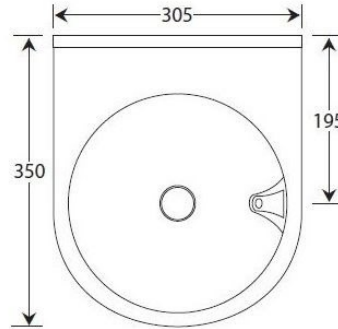

Product Code: DFBFFS-A

Combined Drinking Fountain & Bottle Filler - Adult Height

Product Code DFBFFS-A

- Stainless steel floorstanding drinking fountains with WRAS approved bubbler and bottle filling valve tap.
- Adult height under shroud to conceal pipework and trap.
- 1/3rd thicker than most of our competitors drinking fountains.
- Rounded front design for safety.
- Complete with standard WRAS approved shielded chrome press button drinking water bubbler and bottle filler valve.
- Supplied with fixing bracket, frame, shroud and 32mm waste fitting.
- Recommended for many applications, including schools.
- Tested to 2.0 Bar pressure.
- Please ensure that these are drained down and isolated in cold weather to avoid damage to the bubbler.
- To ensure the proper functioning and longevity of this unit, a Y-strainer or filter must be installed as part of the water supply system. The Y-strainer / filter is essential for protecting the internal components and maintaining the correct flow characteristics of the tap. Failure to install a Y-strainer or filter will result in the warranty being void.

Size

- 350mm front to back.
- 305mm wide.
- 915mm high plus 75mm splash back.

Delivery

- From stock usually 1 to 3 working days.

Optional Extras

- 32mm plastic bottle trap.
- Y-strainer.
- H2O sign.

**All pictures shown are for illustration purpose only and may be subject to change without notice. Actual product may vary due to product enhancement.
All dimensions shown are for guidance only and may be subject to change or alteration without notice. All items manufactured or purchased separately from a third party to fit our products should be checked against the actual dimensions of the physical product before purchase. We will not be liable for third party costs and consequential loss associated with the items not fitting third party components.**