

Infra Red Sensor Tap

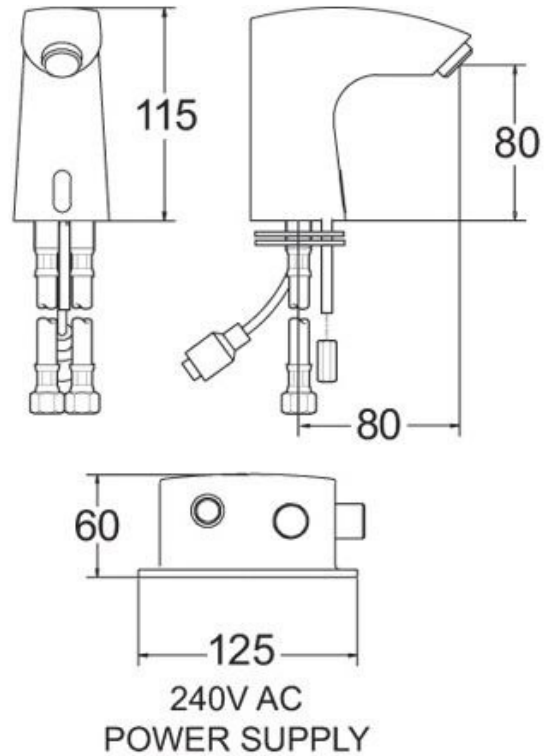

Product Code: S1D

Sensor Operated Basin Tap With Battery And Mains Supply

Product Code: S1D

- Infra red sensor operated basin tap.
- Chrome plated brass body.
- Scratch resistant sensor window.
- Single inlet for cold or pre-mixed water.
- Control box for mains supply, with battery back up, or run from batteries (requires 4 x AA batteries).
- Moisture and water resistant control unit.
- WRAS approved.
- 2 years manufacturers warranty against defects.
- 35mm tap hole required.

Water Pressure

- Minimum pressure required 0.5 Bar.

Delivery

- Usually 1 to 3 working days.

All pictures shown are for illustration purpose only and may be subject to change without notice. Actual product may vary due to product enhancement. All dimensions shown are for guidance only and may be subject to change or alteration without notice. All items manufactured or purchased separately from a third party to fit our products should be checked against the actual dimensions of the physical product before purchase. We will not be liable for third party costs and consequential loss associated with the items not fitting third party components.